



smart
vision lights

DFLW-200-4Z Dark Field RING LIGHT KIT

ZONE LIGHT | WASHDOWN

PRODUCT DATA SHEET

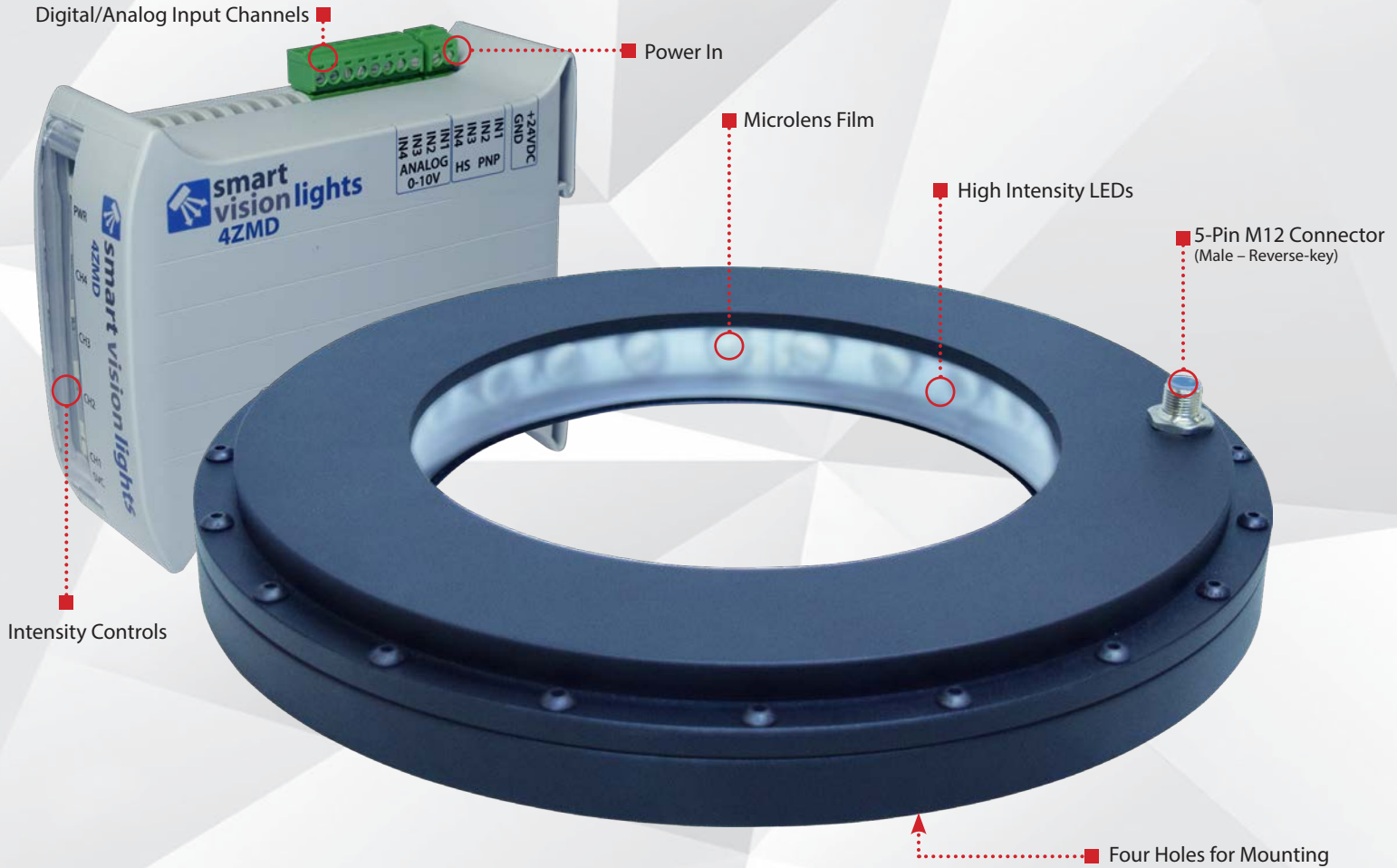

Warranty
10
YEAR

Compliant
IEC
62471

Compliant
CE
RoHS

Rated
IP
68

Connector
5-PIN
M12

PRODUCT HIGHLIGHTS

- ✓ Four individual zones built into a single light
- ✓ Kit includes the 4ZMD-750, which allows for continuous operation or OverDrive™ strobe mode for each channel
- ✓ Built-in individual intensity control channels for either continuous operation or OverDrive™ strobe mode
- ✓ Microlens film directs a beam of light at a 25° angle towards an object, resulting in a high concentration and uniform field of illumination



PRODUCT DESCRIPTION

DFLW-200-4Z

The DFLW-200-4Z Dark Field Washdown Ring Light is IP68 rated and comes in an anodized black aluminum housing. The DFLW-200-4Z has four zones, making it a quadrant light in which each individual zone can be controlled independently of each other.

4ZMD-750

The 4ZMD is an external driver that permits control of up to four separate light zones either independently or simultaneously, in any combination. The 4ZMD has independent intensity controls and built-in Multi-Drive™, allowing a range to be set from 10%–100% for continuous operation or OverDrive™ strobe mode. **The maximum continuous current for the 4ZMD-750 is 750 mA when connected to the DFLW-200-4Z.**

When connected to a LED Light Manager (LLM), each individual channel can be set to continuous on, off, or any intensity level in between, and even OverDrive™ strobe mode. **For more information about the LLM, visit smartvisionlights.com/products/llm.**



WHAT'S INCLUDED

When you order a DFLW-200-4Z ring light, such as the DFLW-200-4Z-WHI, the following item is included:

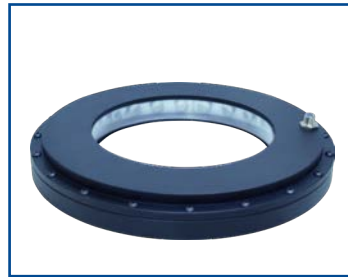

DFLW-200-4Z requires an external constant current driver with maximum 750 mA per channel.

DFLW-200-4Z
RING LIGHT

When you order a DFLW-200-4Z ring light kit, such as the DFLW-200-4Z-WHI-KIT, the following items are included:



DFLW-200-4Z
RING LIGHT

+



4ZMD-750
DRIVER

+



5PM12-J2000-KR
CABLE



RESOURCE CORNER

Additional resources, including CAD files, videos, and application examples, are available on our website.



PRODUCT SPECIFICATIONS

DFLW-200-4Z

PER CHANNEL	CONTINUOUS OPERATION	OVERDRIVE™ STROBE MODE
Maximum LED Input Current	mA	2.0 A
Input Connector	5-pin M12 connector (male — reverse-key)	
Strobe	Not applicable	Max. 50 ms
Duty Cycle	Not applicable	Max. 10%
Ambient Temperature	0°–45°C (32°–114°F)	
IP Rating	IP68	
Weight	~120 g	
Warranty	10 year. For complete warranty information, visit smartvisionlights.com/warranty	
Compliances	CE, RoHS, IEC 62471	

NOTE:

The DFLW-200-4Z requires an external constant current driver, such as the recommended 4WMD-750.

4ZMD-750

OUTPUT PER CHANNEL	CONTINUOUS OPERATION	OVERDRIVE™ STROBE MODE
Electrical Input	24VDC +/- 5%	
Operating Current (No Load)	70 mA	
Electrical Input Connector	2-position screw terminal block — 14 AWG max wire size	
Number of Input Channels	4	
Input Connector	8-position screw terminal block — 14 AWG max wire (4 for PNP and 4 for analog)	
Input Channel Current	PNP input: 4 mA @ 4VDC 10 mA @ 12VDC 20 mA @ 24VDC	
Strobe Duration	N/A	Min. 10 µs Max. 50 ms (see SafeStrobe™ Technology for more information)
Duty Cycle	N/A	Max. 10% (see Duty Cycle for more information)
Analog Intensity	The output is adjustable from 10%–100% of intensity by applying 1–10VDC signal	OverDrive™ Strobe Mode: Apply 0VDC
Output Channels	4 channels for light zones	
Output Connector	5-pin M12 connector (female – reverse-key)	
Indicator Lights	Power on = Green light Individual channel = Yellow light Service = Red light	
Mounting	DIN rail	
Ambient Temperature	-18°–40° C (0°–104° F)	
Ambient Humidity	0–95% non-condensing	
Weight	~230g	
Warranty	3 years. For complete warranty information, visit smartvisionlights.com/warranty	
Compliances	CE, RoHS	

TOTAL INPUT PER UNIT (MAX)	CONTINUOUS OPERATION	OVERDRIVE™ STROBE MODE
Input Current	2.1 A	19 A
Input Power	50.4 W	460 W



MICROLENS FILM

When combined with high-power LEDs, the microlens turning film directs a beam of light at a 25° angle toward the object, resulting in a high concentration and uniform field of illumination. This technique allows for a large-diameter dark field ring light to have an extended working distance while maintaining light intensity and uniformity.

The microlens requires the bottom of the light to be pointed towards the object being inspected. The bottom is the side without the connector.

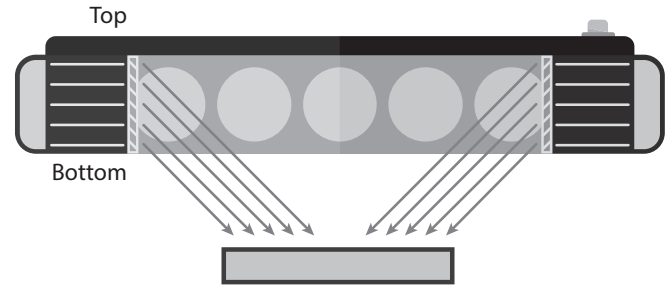

LED COLOR ACCURACY

To ensure accurate color matching between lights, Smart Vision Lights features a color consistent, 3-step MacAdam ellipse LED package with a nominal 5700 K color temperature.



LIGHT PATTERNS

LIGHTING ILLUMINATION FOR THE DFLW-200-4Z

Continuous Operation Mode		
Typical Output Performance	Illuminance (Lux)	
	1 Zone	All Zones
Distance = 100 mm	25,500	102,000

OverDrive™ Mode		
Typical Output Performance	Illuminance (Lux)	
	1 Zone	All Zones
Distance = 100 mm	123,000	495,000

Smart Vision Lights recommends using the DFLW-200-4Z at a working distance between 50 mm and 200 mm.

The DFLW-200 Ring Light produces a uniform light pattern.

WD = Working Distance

Grid set to 30 mm x 30 mm

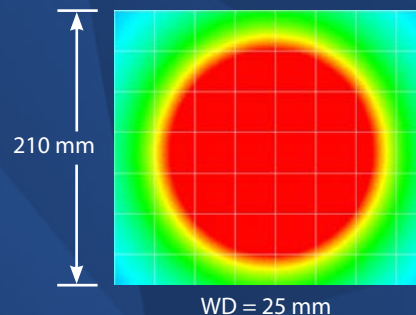



MULTI-DRIVE™

Multi-Drive™ offers the best of both worlds. Continuous operation and OverDrive™ mode (HIGH output strobe/pulse) are available in a single light. Other advantages of Multi-Drive™ include faster imaging and capture/freeze motion on high-speed lines.



The Multi-Drive™ feature allows the user to run the light continuously or in OverDrive™ at the maximum allowed intensity by simply setting the product configuration. OverDrive™ strobe mode has **up to five times** the power of continuous operation.



SAFESTROBE™ TECHNOLOGY

SafeStrobe™ technology is a unique technology that applies safe working parameters to ensure high-current LED's are not damaged by driving them beyond their limits, such as maximum strobe time or duty cycle. This is especially beneficial for overdriving our high-current LED's.



MOUNTING

Mounting options include four M6 threaded holes located on the DFLW-200-4Z.

Hardware included with light:

(2) M6 screws (hex)



M6 threaded hole



EYE SAFETY

According to IEC 62471:2006. Full documentation available upon request.



Notice

Exempt Group: No photobiological hazard to eyes or skin even for continuous, unrestricted use. Applicable for wavelength 625.

Caution

Risk Group 1: Possibly hazardous optical radiation emitted from this product. Do not stare at operating lamp. May be harmful to eyes. Safe for most applications except prolonged exposure. Applicable for wavelengths 470, 530, and WHI.



ILLUMINATION

The DFLW-200-4Z Dark Field Ring Light works best for:

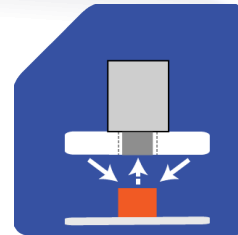

Dark Field

OUTPUT CONFIGURATION

Using the Reverse-Key 5-pin M12 Connector

When connecting a Smart Vision Lights four-zone lights to the 4ZMD, a reverse-key 5-pin M12 cable is required. All Smart Vision Lights four zone lights come equipped with a 5-pin reverse-key connector.

The reverse-key 5-pin M12 connector simplifies connecting lights to the 4ZMD, with very little wiring needed.

4ZMD

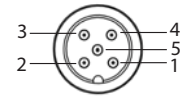

Reverse-Key 5-pin M12 Connector (female)

DFLW-200-4Z

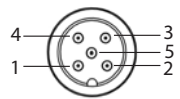

Reverse-Key 5-pin M12 Connector (male)

5-Pin M12 Connectors (Female) Pin Layout

Pin	Channel	Color
1	Common	Brown
2	1	White
3	2	Blue
4	3	Black
5	4	Green/Yellow

NOTE:

Smart Vision Lights uses reverse-key cables that have a blue-grey tip on the connectors.

INPUT CONFIGURATION

Using Input Terminal Block

Input terminal block is also used when connecting to the LED Light Manager (LLM). Smart Vision Lights recommends using the cable provided (part number: IC-400) to connect the 4ZMD driver to the LLM.

LLM Output Channels	4ZMD Input Channels
DO1	PNP IN1
DO2	PNP IN2
DO3	PNP IN3
DO4	PNP IN4
DO5/AO1	Analog 1
DO6/AO2	Analog 2
DO7/AO3	Analog 3
DO8/AO4	Analog 4

ADJUSTING INTENSITY

The 4ZMD allows for the control of up to four individual channel intensity levels. Depending on how each channel is wired, its intensity can be adjusted for either continuous operation or OverDrive™ strobe mode. Each channel intensity can be adjusted either in continuous operation or OverDrive™ strobe mode, but not both modes simultaneously. Each channel has a yellow indicator light that will illuminate when the channel is active.

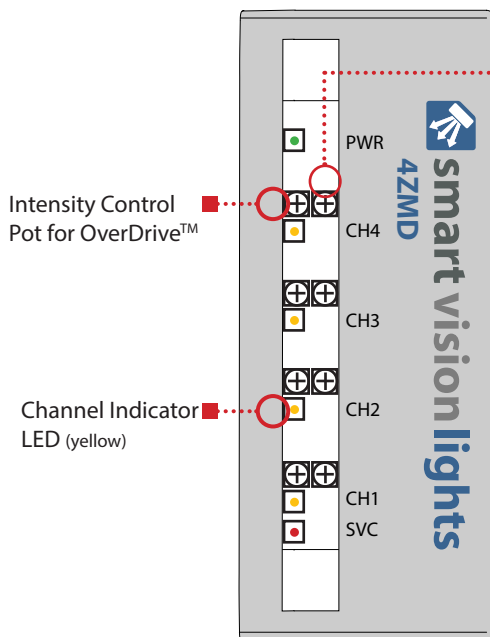

Intensity Control Pot for Continuous Operation

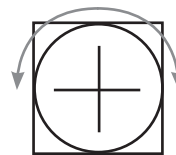

270° turn pot
Clockwise = Increase intensity
Counterclockwise = Decrease intensity

NOTE:

When in continuous operation, channel intensity can be individually adjusted using 1–10V DC on the analog input.

NOTE:

When managing the 4ZMD with the LED Light Manager (LLM), turn the intensity pots on the front of the 4ZMD fully clockwise to ensure intensity is completely controlled by the LLM.



UNDERSTANDING ZONES

The DFLW-200-4Z has four individual built-in zones that can act independently. Each zone can be set to continuous on, off, any intensity level in between, and even OverDrive™ strobe mode. Intensity levels can be set by programming a LLM to control the zones or using the intensity controls on the front of the 4ZMD (see Managing Zones and Adjusting Intensity).

The DFLW-200-4Z allows any combination of the four zones to be turned on at the same time, including adjacent and opposing zones.



MANAGING ZONES

Connect the LLM to the 4ZMD driver. The LLM allows for easy control of each individual zone. The event programmed within the LLM can contain multiple sequences. Users can set each zone independently to continuous on, off, or any intensity level in between, and even OverDrive™ strobe mode.

For more information about the LLM, visit: smartvisionlights.com/products/llm.



WIRING CONFIGURATION

Input Channels for 4ZMD

Power In — Power source

HS PNP — High-speed PNP strobing/trigger

Analog 0–10 V — Input for setting intensity for continuous mode (1–10 V DC) or OverDrive™ strobe mode (0 V DC)

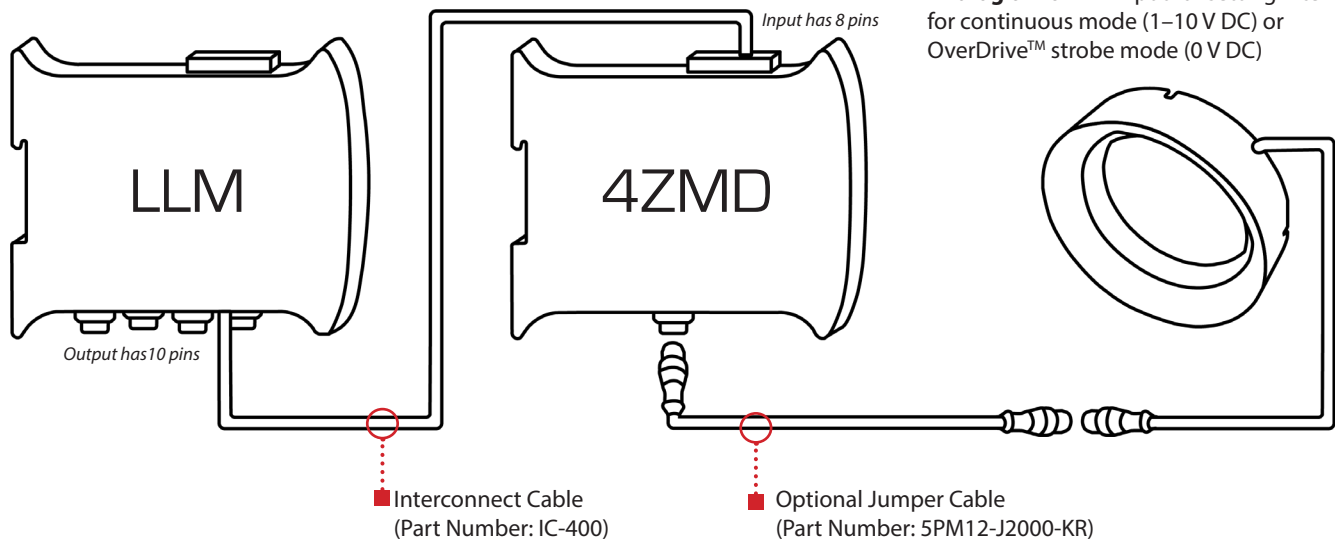



PART NUMBER

DFLW-200-4Z -



COLOR:



HOUSING

Leave blank for Anodized Black Aluminum
ST = Stainless Steel



KIT

Leave blank for only light.
KIT = Kit includes light and external driver

Part Number Examples:

DFLW-200-4Z-625 DFLW-200-4Z, 625 nm red wavelength, standard housing light only

DFLW-200-4Z-WHI-KIT DFLW-200-4Z, WHI white, standard housing, light and external driver

DFLW-200-4Z-WHI-ST-KIT DFLW-200-4Z, WHI white, stainless steel housing, light and external driver

Additional wavelength available upon request



DUTY CYCLE (OVERDRIVE™ MODE ONLY)

This section applies only if light is in OverDrive™ strobe mode.

Maximum Duty Cycle for OverDrive™ light is 10% (0.1)

The Duty Cycle (D) is related to the Strobe Time (ST) and Rest Time (RT).

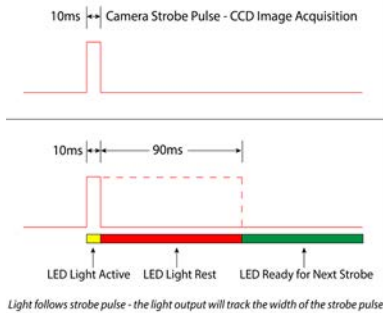

Note: Strobe time is limited by the strobe rate.

Calculating Rest Time

$$RT = \frac{ST}{D} - ST$$

RT = Rest Time
 ST = Strobe Time
 D = Duty Cycle

Example

$$90 \text{ ms} = \frac{10 \text{ ms}}{.1} - 10 \text{ ms}$$

Rest Time is 90 ms for 10 ms Strobe Time

Calculating Strobe Rate

$$SR = \frac{D}{ST}$$

SR = Strobe Rate (strokes per second)
 ST = Strobe Time (seconds)
 D = Duty Cycle

Example

$$1000 = \frac{0.1}{0.0001}$$

Strobe Rate is 1000 strokes per second

Calculating Duty Cycle

$$D = ST \times SR$$

SR = Strobe Rate (strokes per second)
 ST = Strobe Time (seconds)
 D = Duty Cycle

Example

$$0.1 = 0.0001 \times 1000$$

Duty Cycle is 10% (0.1)



STAINLESS-STEEL VERSION

The DFLW-200-4Z is available in a stainless-steel housing. Stainless-steel housing is recommended for any food grade application. Lead time for the stainless-steel version of the DFLW-200 is longer than that of the anodized black aluminum housing version.



316 Stainless-Steel Housing

Add - ST to end of part number for Stainless-Steel



ACCESSORIES

Jumper Cable



Lengths	Part Number
2000 mm	5PM12-J2000-KR

Interconnect Cable



Lengths	Part Number
400 mm	IC-400



GLOSSARY

This glossary covers all Smart Vision Lights product families; some content in this section may not apply to this specific light.

TERMINOLOGY

OverDrive™ Light includes an integrated high-current strobe driver for complete LED light control.

Continuous Operation Light stays on continuously.

Multi-Drive™ Combines continuous operation and OverDrive™ strobe (high-current strobe operation) modes into one easy-to-use light.

Built-In Driver The built-in driver allows full function without the need of an external driver.

Camera to Light Connecting the light directly to the camera, without the need for additional controllers or equipment.

Polarizers Filters that reduce reflections on specular surfaces.

Diffuser Used to widen the angle of light emission, reduce reflections, and increase uniformity.

TYPES OF ILLUMINATIONS

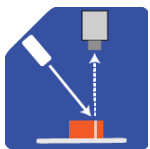

Projector

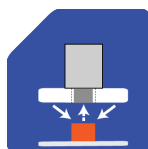

Dark Field

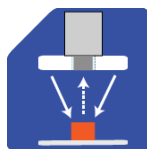

Radial



Bright Field

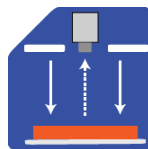

Direct

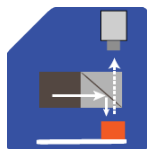

Axial

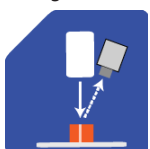

Line

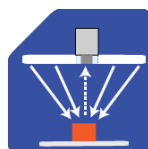

Diffuse Panel

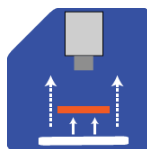

Backlight

COMMON COLOR/WAVELENGTHS LEGEND

Wavelength options range from 365 nm to 1550 nm.
Additional wavelengths available for many light families.

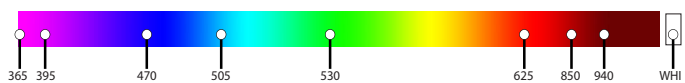

*See Part Number section for **this light's** available standard wavelengths.



Short Wave Infrared LEDs are available in 1050 nm, 1200 nm, 1300 nm, 1450 nm, and 1550 nm.