

B4820



IMPERX: Technically superior products, full tech support, rapid-response customer care. "Bobcat 2.0" adds many new features, lens control, more memory and enhanced image quality. Each easy to use Bobcat is supported by IMPERX professionals.

INTERFACES AVAILABLE:

Resolution
 Sensor
 Sensor Format

Pixel Size
 Frame Rate Standard Clock
 Frame Rate Overclocked
 Maximum Frame Rate
 Minimum S/N Ratio
 Output Format

Analog Gain Control
 Black Level Control
 Digital Gain and Offset
 RGB Gain and Offset
 White Balance
 Shutter Speed
 Exposure Control
 Long Integration
 Regions of Interest (ROI)
 Binning H/V
 Trigger Inputs

Trigger Options

Trigger Modes

Double Trigger (PIV) Interframe
 External Inputs/Outputs
 Strobe Output
 RS232 Interface
 Pulse Generator
 Image Overlay
 Image Enhancement

Internal DDR Memory
 On Board FIFO (GEV & PoE)
 Gamma Correction
 Data Corrections

Minimum Illumination
 Lens Mount

Video Iris Control
 Iris, Zoom Focus Control
 Supply Input Range
 Power Consumption
 Size – Width/Height
 Size – Length

Weight
 Vibration, Shock
 Environmental
 Humidity
 MTBF
 Regulatory

Camera Link® Base (PoCL), GigE Vision, PoE, CoaXPress
 4872 x 3248 (std.), 4904 x 3280 (max.)

KAI-16000, CCD
 36.29mm (H) x 24.27mm (V) 43.3mm diagonal
 43.3mm optical format

7.4 μ m
 30 MHz / 3.2 fps
 40 MHz / 4.2 fps
 24.8 fps
 60dB

Mono CCD: 8, 10, 12, 14-bit (Single only)
 Color CCD: 8, 10, 12, RGB 24

Manual, Auto: 0 - 36dB 1024 steps

Manual, 1024 steps

Manual

Manual

Manual, auto, off

1 μ s/step, 1/67,000 to 1/3 sec (nom)

Manual, auto, external

Up to 16 seconds

7 ROIs, any line to any line, any pixel to any pixel

1x, 2x, 3x, 4x, 8x (Independent for H & V)

External (TTL via IN1/IN2), pulse generator,

software, computer

Level, edge, pulse width, internal exposure,

up to 16 seconds trigger delay, debounce

Free-run, standard, double, fast, asynchronous,

frame accumulation

Time: 200 nanoseconds

2 IN, 2 OUT, user programmable

2 strobes, programmable position and duration

Yes, programmable

Yes, programmable

Optical center, programmable H & V lines

Threshold, contrast enhancement, knee correction,

horizontal flip, negative image, bit shift (+/- 7 places)

2Gb (256 MB)

1Gb (128 MB)

G=1.0, G=0.45, user upgradeable LUT

Defective/hot pixel correction (static, dynamic), FFC,

black level, vertical smear

1 Lux, F/ 1.4

F-Mount (Default), C, M42, EOS, Rodenstock,

Custom OEM

Auto, programmable

Manual, user programmable

12VDC (10V - 15V), 1.5 A inrush

CLB 3.8 W, GEV 5.5W, PoE 6.7W, CXP TBD

60mm (W) x 60mm (H) – Applies to all interfaces

CLB 45.1mm (L), GEV 63.2mm (L), PoE 76.8mm (L),

CXP 52.8mm (L)

CLB 330g, GEV 378g, PoE 511g, CXP 366g

100g (20-200) HZ XYZ, 1000g

-40°C to +85°C Operating, -50°C to +90°C Storage

10% to 90% non-condensing

>660,000 hours @ 40°C (Telcordia SR-332)

FCC 15 part A, CE, RoHS

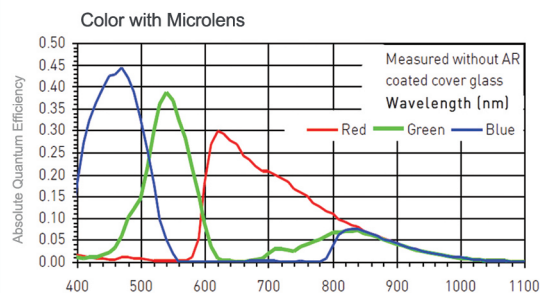
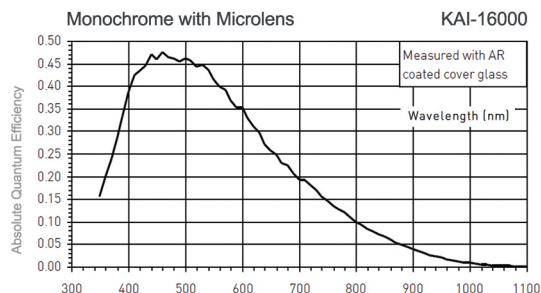

BOBCAT 2.0 B4820 Specifications

GigE Vision(Without PoE)

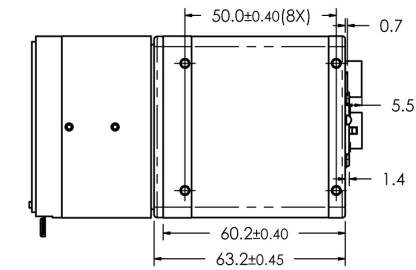

GigE Vision(With PoE)

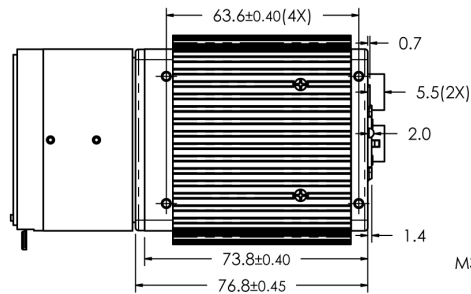

Camera Link

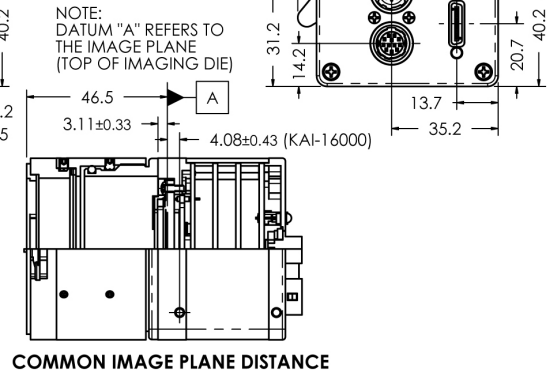
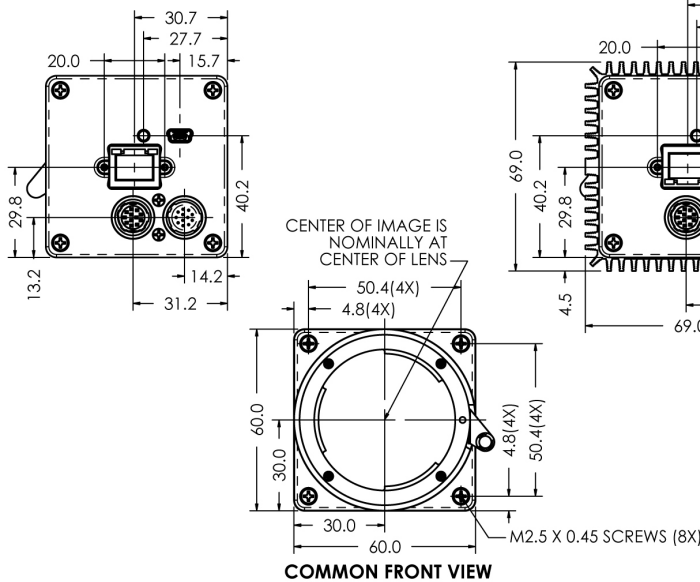
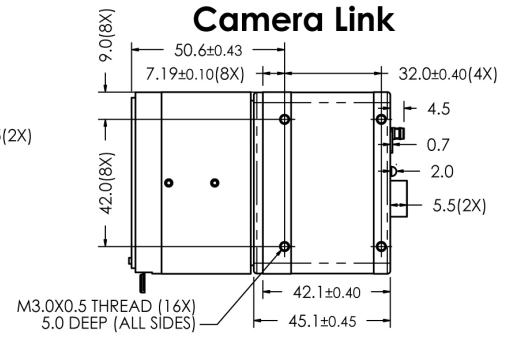

Hirose Connectors

Power and I/O Interface

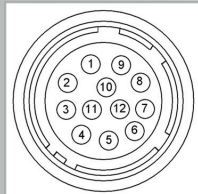

- | | |
|-------------------|-----------------|
| 1 12V DC Return * | 7 OUT1 Signal |
| 2 +12V DC* | 8 IN1 Signal |
| 3 IRIS VCC | 9 IN2 Signal |
| 4 IRIS Video | 10 IN1/2 Return |
| 5 IRIS Return | 11 Reserved |
| 6 OUT1/2 Return | 12 OUT2 Signal |

Connector: Hirose HR 10A- 10R- 12PB(71)
*Not connected for CXP

Lens Control/RS232

See manual for PIN information

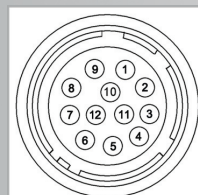

- | | |
|---------------|-------------|
| 1 IRIS Return | 7 FOCUS + |
| 2 IRIS VCC | 8 ZOOM - |
| 3 IRIS Video | 9 ZOOM + |
| 4 IRIS - | 10 UART_COM |
| 5 IRIS + | 11 UART_RX |
| 6 FOCUS - | 12 UART_TX |

Connector: Hirose HR 10A- 10R- 12SB(71)
* Canon EOS control available

CoaXPress

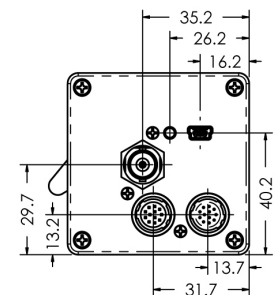
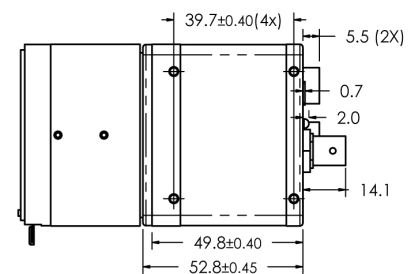

B4820 Ordering Information

Interfaces available

- Camera Link® Base (CLB)
- GigE Vision (GEV / PoE)
- CoaXPress (CXP)

Sensor types available

- Monochrome
- Bayer Color

Accessories (Sold separately)

- PS12v04-Power Supply w/ 1 input and 1 output
- PS12v05-Power Supply (as above) and Video Iris

IMPERX
WWW.IMPERX.COM



bobcat-B4820,Rev1